

4A Micro Hybrid FPC-to-Board Connectors

BM22 Series

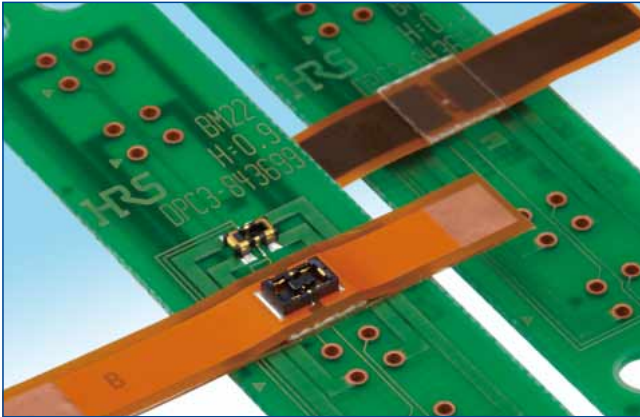

■ Features

1. 4A current rating

The space-saving design utilizes two power contacts that can carry up to 4A of current, and signal contacts that can also carry 0.3A of current. This is all delivered in a small connector that features a small mounting depth of 2.64mm. (Fig.1)

2. Two point contact structure

The structure utilizes two points on each contact to ensure a secure connection for both types of contacts (power and signal). (Fig.2.3)

3. Good mating operability

The connector contributes to the enhanced mating operability by giving a click feeling which is effective in preventing incomplete mating, and mating self-alignment of 0.3mm which is secured by the guide ribs.

63% Reduction in footprint (Compared to the dimensions of Hirose's W-to-B DF57H)

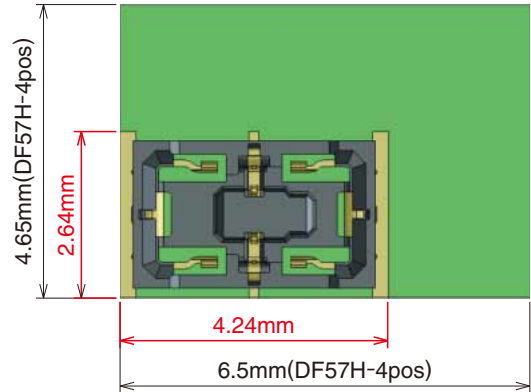

Fig.1

Vacuum Pick-up Area

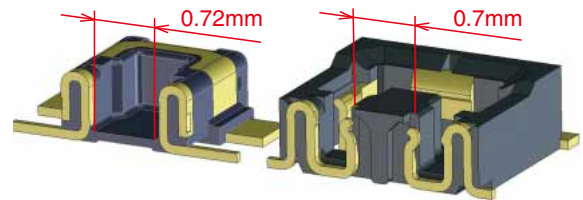

Fig.2

Mating Cross-Section Diagram

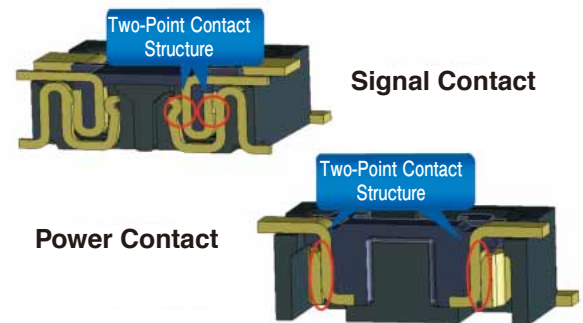

Fig.3

Product Specifications

Ratings	Current rating	Power contact : 4A Signal contact : 0.3A	Operating temperature range	-35 to 85°C (Note 1)	Storage temperature range	-10 to 60°C (Note 2)
	Voltage rating	50V AC/DC	Operating humidity range	20 to 80%	Storage humidity range	40 to 70% (Note 2)

Item	Specification	Conditions
1. Insulation resistance	Minimum of 100MΩ	Measured at 100V DC
2. Withstanding voltage	No flashover or insulation breakdown	Conduct 150V AC for 1 minute
3. Contact resistance	Signal contact : Max of 50mΩ Power contact : Max of 30mΩ	Measured at 20mV AC, 1kHz, 1mA
4. Vibration	No electrical discontinuity of 1μs or longer	Frequency : 10 to 55Hz, single amplitude of 0.75mm, 10 cycles in each of 3 axis directions for 5 minutes / cycle
5. Humidity	Contact resistance : Signal contact Max of 50mΩ Power contact Max of 30mΩ Insulation resistance : Min of 50MΩ	96 hours at a temperature of 40 ±2°C and a humidity range from 90 to 95%
6. Temperature cycle	Contact resistance : Signal contact Max of 50mΩ Power contact Max of 30mΩ Insulation resistance : Min of 100MΩ	-55°C : 30 minutes → 85°C : 30 minutes, 5 cycles
7. Durability	Contact resistance : Signal contact Max of 50mΩ Power contact Max of 30mΩ	10 mating cycles
8. Solder Heat Resistance	No signs of melting or deformity on the molded resin parts and no negative effects on performance.	Reflow : according to the Recommended Solder Profile Hand soldering : Soldering iron temperature 350°C, no more than 3 seconds of contact

Note 1 : Includes temperature rise caused by current flow.

Note 2 : The term "storage" here refers to products stored for a long period prior to board mounting and use. The operating temperature and humidity range covers the non-energized condition of connectors after board mounting and the temporary storage conditions during transportation, etc.

Material

Product	Part	Material	Finish	UL standard
Receptacle / Header	Insulator	LCP	Black	UL94V-0
	Contacts	Copper alloy	Gold plated	—

Product Number Structure

●Receptacles / Headers

BM 22 - * S - V (51)

①
②
③
④
⑤

① Series name : BM 22 / BM 22L	④ Termination type V : Straight SMT
② Number of contacts : 4 (2 for signal and 2 for power) 6 (4 for signal and 2 for power)	
③ Connector type : S : Receptacle P : Header	⑤ Gold plated specification and packaging status (51) : Gold plate thickness 0.05μm Embossed tape packaging (10,000pcs/reel) (53) : Gold plate thickness 0.05μm Embossed tape packaging (1,000pcs/reel)

Receptacles

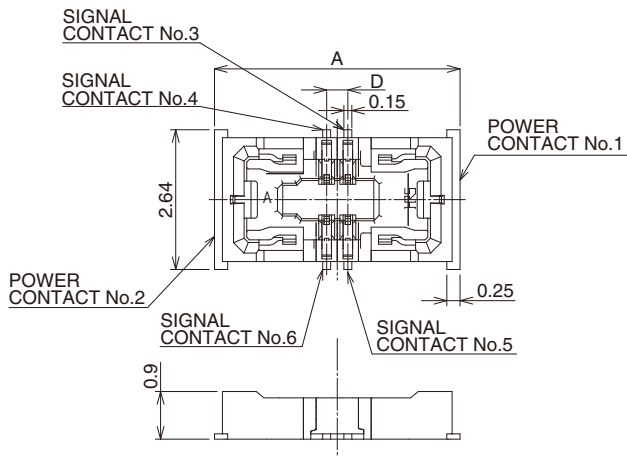

Recommended PCB layout

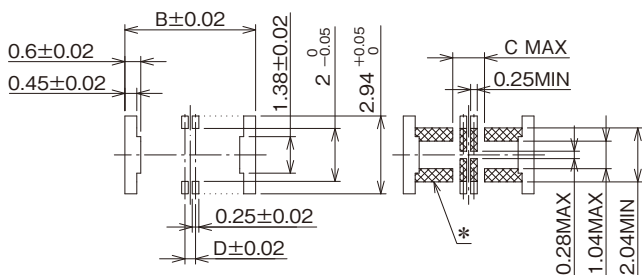

Recommended metal mask dimensions (mask thickness: 100 μm)

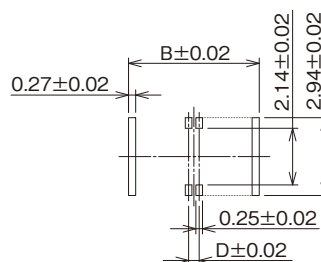

*: No conductive trace area

(No of routing different circuit; however the same circuit that is connected to the footprint is allowed, and soldering resist must be applied over the trace.)

Part No.	HRS No.	No. of Contacts	A	B	C	D
BM22-4S-V(51)	677-1002-6 51	4	4.24	4.54	0.8	—
BM22-6S-V(51)	677-1004-1 51	6	4.64	4.94	1.2	0.4

Note: This product is packaged on reels; please place your orders for full reel quantities.

Headers

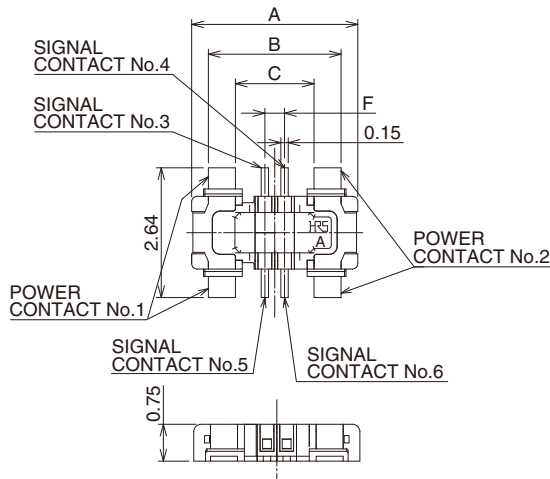

Recommended PCB layout

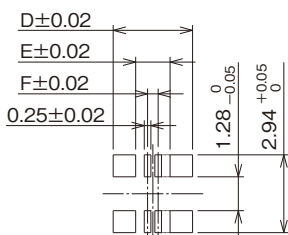

Recommended metal mask dimensions (mask thickness: 100 μm)

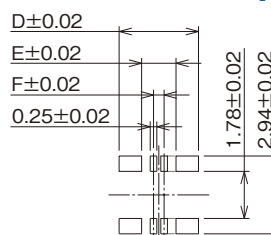

Part No.	HRS No.	No. of Contacts	A	B	C	D	E	F
BM22L-4P-V(51)	677-1006-7 51	4	3	2.3	1.2	2.6	0.9	—
BM22L-6P-V(51)	677-1007-0 51	6	3.4	2.7	1.6	3.0	1.3	0.4

Note: This product is packaged on reels; please place your orders for full reel quantities.

◆ Embossed Tape Dimensions (complies with JIS C 0806)

● Receptacle

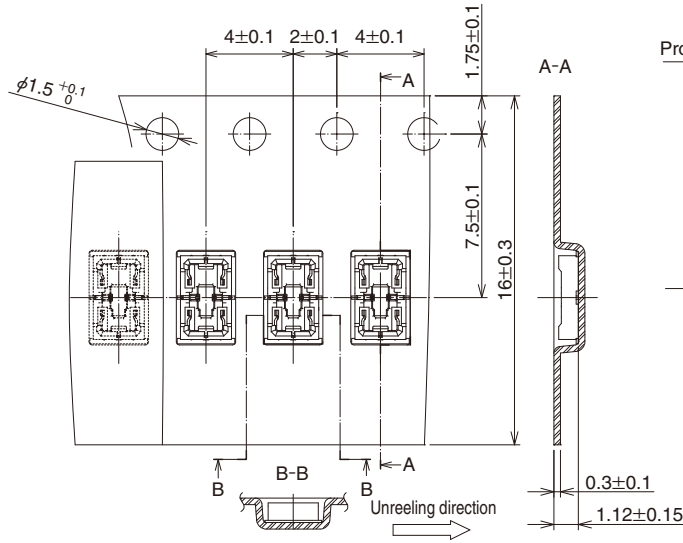

● Reel dimensions

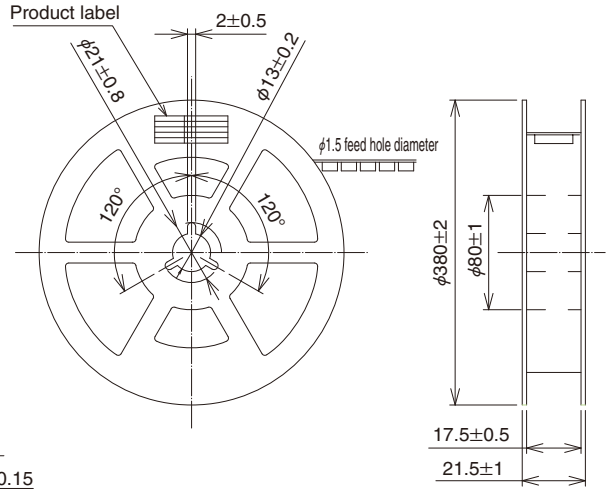

● Header

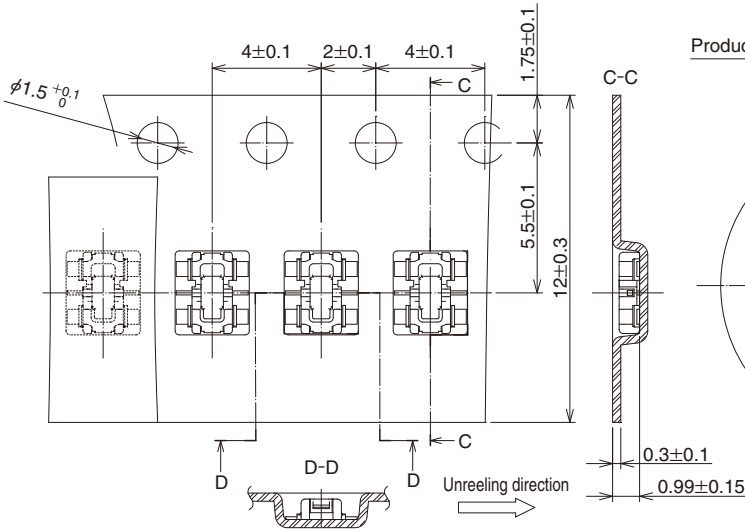

● Reel dimensions

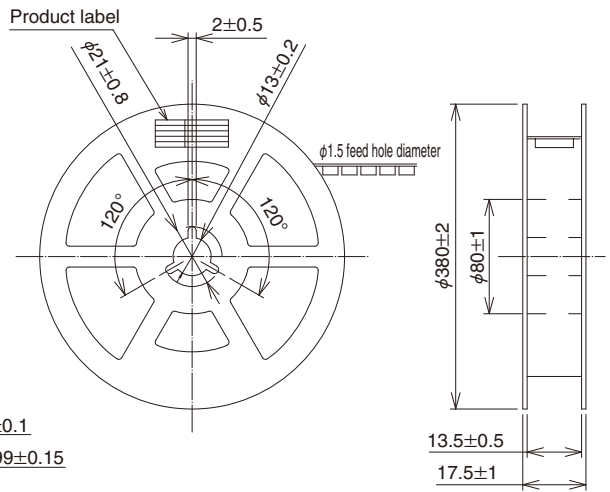

◆ Usage Recommendations

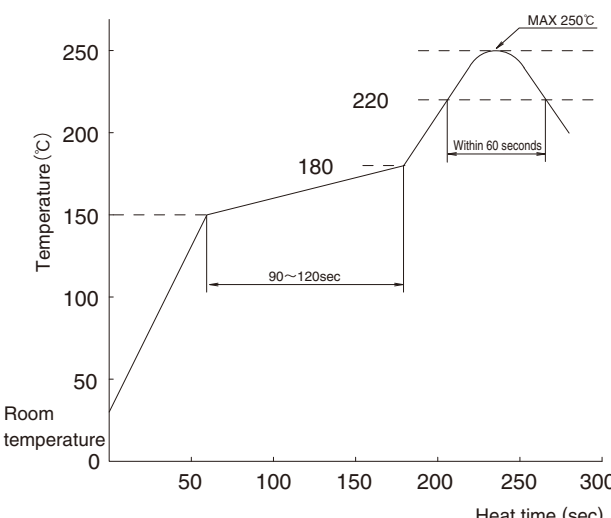

<p>1. Recommended Soldering Profile</p>	 <p>[Condition]</p> <ol style="list-style-type: none"> 1. Peak temperature : Maximum of 250°C 2. Heat section : 220°C min., within 60 seconds 3. Preheat section : 150 to 180°C, 90 to 120 seconds 4. Number of reflow cycles : Maximum of 2 cycles <p>Note 1: The temperature represents the PCB surface temperature in the vicinity of the connector lead section. Note 2: For the use of Nitrogen reflow, mount the connectors with an oxygen density of 1,000 ppm or higher. Consult Hirose for the condition less than 1,000 ppm.</p>
<p>2. Recommended manual soldering condition</p>	<p>Soldering iron temperature: 340 ±10°C, soldering time: within 3 seconds</p>
<p>3. Recommended stencil thickness and open area ratio to PCB pattern area</p>	<p>Thickness: 0.1 mm Open area ratio: 85% for signal contact, and 60% for power contact on the Receptacle side. 70% for both contacts on the Plug side</p>
<p>4. Board warpage</p>	<p>Maximum of 0.02 mm in the center of the connector, while using both ends of the connector as reference point</p>
<p>5. Cleaning conditions</p>	<p>We do not recommend cleaning these connectors. Cleaning them may alter the mating/un-mating operations. If you do clean them, make sure you test that these operations have not been compromised prior to use.</p>
<p>6. Precautions</p>	<ul style="list-style-type: none"> ●Do not mate or un-mate these connectors until they are mounted, failure to follow this precaution can lead to deformation or damage to these connectors. ●Provide another form of support to the PCB, this connector was not designed to be the main form of support. ●When mating/un-mating this connector, do not apply excessive twisting forces onto the connector. These forces can damage the contacts and alter its performance. ●Do not apply excessive amounts of flux as it may cause the flux to wick. ●There may be a slight variance in the color of the molding between production lots; this variance will not affect the performance of the connector. ●Refer to the next page for the handling precautions when mating and un-mating these connectors. ●If the connector becomes disconnected due to impact, a fall or a counterforce to the FPC, it may be necessary to hold the connector in place with an addition to the device's case or other cushioning material to hold the connector in place.

Apr.1.2016 Copyright 2016 HIROSE ELECTRIC CO., LTD. All Rights Reserved.

◆ Handling Precautions when Mating Connectors

<p>BM22-S-V</p> <p>BM22L-P-V</p>	
<p>Incorrect</p> <p>Incorrect</p>	<p>Prior to mating, locate the guidance ribs and align the header. Do not apply excessive force during the mating process as it may damage the contacts.</p>
	<p>When the connector has been correctly aligned, the header will be parallel to the receptacle. An even force can now be applied to the header to mate it with the receptacle until it is fully mated.</p>

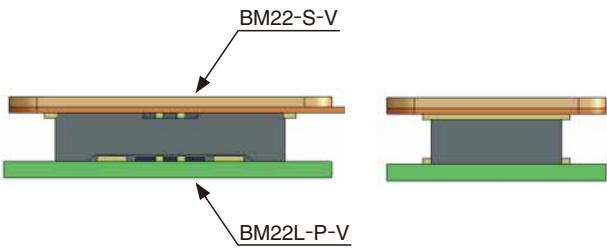
◆ Handling Precautions when Un-mating Connectors

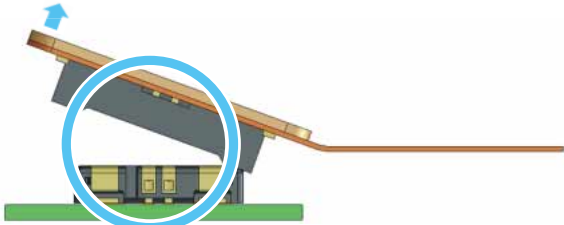
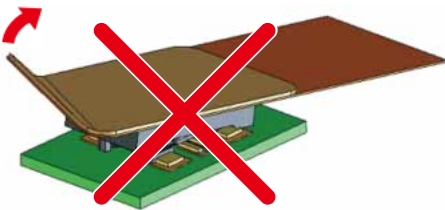
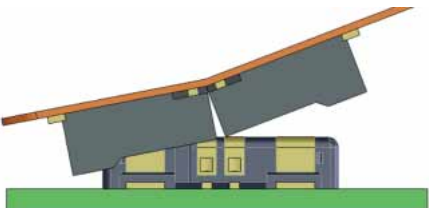
 <p>BM22-S-V</p> <p>BM22L-P-V</p>	
 <p>Correct</p> <p>Correct</p>	<p>To un-mate this connector, lift evenly across the header. Make sure that each side of the connector stays parallel to the other.</p>
 <p>Pitch orientation Correct</p>	<p>If circumstances prevent the connectors from staying parallel to each other, then one side may be lifted as shown in the diagram. This method is only approved if the connector is mounted onto an extremely rigid circuit board. If the board were to warp during this process it may result in damage to the connector or its solder joints.</p>
 <p>Corner orientation Incorrect</p>	<p>Do not try to disconnect these connectors by pulling on one side or a single corner, or to un-mate it when it is hasn't been securely mounted onto a rigid FPC. These actions may lead to deformities and ultimately a damaged connector. Prior to the mounting of these connectors we recommend that you check the rigidity of your FPC to ensure that it meets the standards needed to support these connectors.</p>
	<p>If the FPC is not strong enough by itself, a stiffener may be applied. If the FPC has a low rigidity the connector may break (as shown in the illustration to the left). We recommend a backing of no less than 0.3 mm of glass epoxy and 0.2 mm of stainless material.</p>

USA:

HIROSE ELECTRIC (U.S.A.), INC. HEADQUARTERS
 2688 Westhills Court, Simi Valley, CA 93065-6235
 Phone : +1-805-522-7958
 Fax : +1-805-522-3217
<http://www.hirose.com/us/>

USA:

HIROSE ELECTRIC (U.S.A.), INC. SAN JOSE OFFICE
 3255 Scott Boulevard, Building 7, Suite 101
 Santa Clara, CA 95054
 Phone : +1-408-253-9640
 Fax : +1-408-253-9641
<http://www.hirose.com/us/>

USA:

HIROSE ELECTRIC (U.S.A.), INC. CHICAGO OFFICE
 580 Waters Edge Lane, Suite 205 Lombard IL
 60148
 Phone : +1-630-282-6701
 Mail : inquiries@hirose.com
<http://www.hirose.com/us/>

USA:

HIROSE ELECTRIC (U.S.A.), INC. DETROIT OFFICE (AUTOMOTIVE)
 17197 N. Laurel Park Drive, Suite 253, Livonia,
 MI 48152
 Phone : +1-734-542-9963
 Fax : +1-734-542-9964
<http://www.hirose.com/us/>

THE NETHERLANDS:

HIROSE ELECTRIC EUROPE B.V.
 Hogehillweg #8 1101 CC Amsterdam Z-0
 Phone : +31-20-6557460
 Fax : +31-20-6557469
<http://www.hirose.com/eu/>

GERMANY:

HIROSE ELECTRIC EUROPE B.V. GERMAN BRANCH
 Herzog-Carl-Strasse 4 D-73760 Ostfildern
 (Scharnhäuser Park)
 Phone : +49-711-4560-02-1
 Fax : +49-711-4560-02-299
<http://www.hirose.com/eu/>

GERMANY:

HIROSE ELECTRIC EUROPE B.V. NUERNBERG OFFICE
 Muggenhofer Str. 136 90429 Nuernberg
 Phone : +49-911 32 68 89 63
 Fax : +49-911 32 68 89 69
<http://www.hirose.com/eu/>

GERMANY:

HIROSE ELECTRIC EUROPE B.V. HANOVER OFFICE
 Bayernstr. 3, Haus C 30855 Langenhagen, Germany
 Phone : +49-511 97 82 61 30
 Fax : +49-511 97 82 61 35
<http://www.hirose.com/eu/>

FRANCE:

HIROSE ELECTRIC EUROPE B.V. PARIS OFFICE
 Regus La Garenne Colombes, Place de La Belgique,
 71 Boulevard National La Garenne Colombes, 92250, France
 Phone : +33 (0) 1 7082 3170
 Fax : +33 (1) 7082 3101
<http://www.hirose.com/eu/>

UNITED KINGDOM:

HIROSE ELECTRIC EUROPE BV (UK BRANCH)
 4 Newton Court, Kelvin Drive, Knowlhill,
 Milton Keynes, MK5 8NH
 Phone : +44-1908 202050
 Fax : +44-1908 202058
<http://www.hirose.com/eu/>

CHINA:

HIROSE ELECTRIC (SHANGHAI) CO., LTD.
 1601, Henderson Metropolitan, NO.300, East Nanjing
 Road, Huangpu District, Shanghai, China 200001
 Phone : +86-21-6391-3355
 Fax : +86-21-6391-3335
<http://www.hirose.com/cn/>

CHINA:

HIROSE ELECTRIC (SHANGHAI) CO.,LTD. BEIJING BRANCH
 A1001, Ocean International Center, Building 56# East 4th
 Ring Middle Road, ChaoYang District, Beijing, 100025
 Phone : +86-10-5165-9332
 Fax : +86-10-5908-1381
<http://www.hirose.com/cn/>

CHINA:

HIROSE ELECTRIC TECHNOLOGIES (SHENZHEN) CO., LTD.
 Room 09-13, 19/F, Office Tower Shun Hing Square, Di Wang Commercial Centre,
 5002 Shen Nan Dong Road, Shenzhen City, Guangdong Province, 518008
 Phone : +86-755-8207-0851
 Fax : +86-755-8207-0873
<http://www.hirose.com/cn/>

HONG KONG:

HIROSE ELECTRIC HONGKONG TRADING CO., LTD.
 Room 1001, West Wing, Tsim Sha Tsui Centre, 66
 Mody Road, Tsim Sha Tsui East, Kowloon, Hong Kong
 Phone : +852-2803-5338
 Fax : +852-2591-6560
<http://www.hirose.com/hk/>

TAIWAN:

HIROSE ELECTRIC TAIWAN CO., LTD.
 103 8F, No.87, Zhengzhou Rd., Taipei
 Phone : +886-2-2555-7377
 Fax : +886-2-2555-7350
<http://www.hirose.com/tw/>

KOREA:

HIROSE KOREA CO., LTD.
 250, Huimanggongwon-ro, Siheung-si,
 Gyeonggi-do, Korea, 429-849
 Phone : +82-31-496-7000,7124
 Fax : +82-31-496-7100
<http://www.hirose.co.kr/>

SINGAPORE:

HIROSE ELECTRIC SINGAPORE PTE. LTD.
 10 Anson Road #26-16, International Plaza
 079903, Singapore
 Phone : +65-6324-6113
 Fax : +65-6324-6123
<http://www.hirose.com/sg/>

INDIA:

HIROSE ELECTRIC SINGAPORE PTE. LTD. DELHI LIAISON OFFICE
 Office NO.519, Regus-Green Boulevard, Level5, Tower C,
 Sec62, Plot B-9A, Block B, Noida, 201301, Uttar Pradesh, India
 Phone : +91-12-660-8018
 Fax : +91-120-4804949
<http://www.hirose.com/sg/>

INDIA:

HIROSE ELECTRIC SINGAPORE PTE. LTD. BANGALORE LIAISON OFFICE
 Unit No-403, 4th Floor, No-84, Barton Centre, Mahatma
 Gandhi (MG) Road, Bangalore 560 001, Karnataka, India
 Phone : +91-80-4120 1907
 Fax : +91-80-4120 9908
<http://www.hirose.com/sg/>

MALAYSIA:

HIROSE ELECTRIC SINGAPORE PTE. LTD.
 1-10-07, Suntech @ Penang Cybercity (1164),Lintang
 Mayang Pasir 3,11950, Bayan Baru, Penang, Malaysia.
 Phone : +604-619-2564
 Fax : +604-619-2574
<http://www.hirose.com/sg/>

THAILAND:

HIROSE ELECTRIC SINGAPORE PTE. LTD. BANGKOK OFFICE (REPRESENTATIVE OFFICE)
 Unit 4703, 47th FL., 1 Empire Tower, South Sathorn
 Road, Yannawa, Sathorn, Bangkok 10120 Thailand
 Phone : +66-2-686-1255
 Fax : +66-2-686-3433
<http://www.hirose.com/sg/>



HIROSE ELECTRIC CO.,LTD.

6-3,Nakagawa Chuoh-2-Chome,Tsuzuki-Ku,Yokohama-Shi 224-8540,JAPAN
 TEL: +81-45-620-3526 Fax: +81-45-591-3726
<http://www.hirose.com>
<http://www.hirose-connectors.com>